

.....*June*.....2016

AES – 3C Maritza East I EOOD

and

DIAMOND POWER CENTRAL AND EASTERN EUROPE S.R.O.

**CONTRACT FOR SUPPLY OF SPARE PARTS FOR ASH DISPOSAL SYSTEM
MANUFACTURED BY DIAMOND POWER**

CONTRACT NUMBER: 1057-AG-PPL

This Contract is made on this 8 day of June 2016

BY AND BETWEEN:

- (1) AES – 3C Maritza East I EOOD, a one-person private limited company registered in the Commercial Register with the Registry Agency under Unified ID Code (UIC) 123533834, having its headquarters and registered office in the town of Galabovo 6280, Galabovo Municipality, Stara Zagora region, Bulgaria, represented by Todor Belezhkov, in his capacity as Plant Manager AES Bulgaria (hereinafter referred to as the "Contracting Entity") of the one part

AND

- (2) Diamond Power Central & Eastern Europe s.r.o., a company registered in the Trade Register with the Registry Agency under UIC 28399641, having its headquarters and registered office at V Jircharich 148/4, 110 00 Praha1, Czech Republic, represented by Juha Mustonen, in his capacity as Managing Director of headquarters at Prague (hereinafter referred to as the "Contractor" of the other part,

(each a "Party" and collectively the "Parties").

WHEREAS:

- (A) The Contracting Entity owns and operates a coal-fired power plant called TPP "AES Galabovo", located on the site of the Contracting Entity (as defined below) at Galabovo 6280, Galabovo Municipality, Stara Zagora region;
- (B) This document and the attachments shall constitute the agreement between the Contracting Entity and the Contractor in respect of supply of Goods

THE PARTIES HAVE AGREED AS FOLLOWS:

GENERAL PROVISIONS:

1. Definitions and Interpretations

In this Contract, the following words and expressions will have the following meanings:

„**Contracting Entity**“ means the Party designated as such herein, including its legal and private successors.

„**Due diligence**“ means that level of skill, diligence, prudence, foresight, care and working practices that should reasonably and ordinarily be expected from a skilled and experienced provider, meeting the requirements of the applicable law (dealing with the same type of activity as that of the Contractor under the same or similar circumstances).

„**Delivery Date**“ means the agreed date or deadline for delivery.

„**VAT**“ means value added tax, the amount of which is defined in the Value Added Tax Act.

„**Delivery**“ means the delivery to and unloading of Goods under this Contract on the site of the Contracting Entity or any other place designated by the Contracting Entity, or specified herein as the place of supply of Goods as well as carrying out installation and/or other related supply activities to the satisfaction of the Contracting Entity. "Supply" and "Delivered" shall be construed accordingly.

„**Binding provisions**“ include any law, statute, rules, regulations or regulatory powers, delegated authority or other arrangements, with any amendments thereto, and any other acts the adoption of which such provisions provide for.

„**PPA**“ means the Public Procurement Act.

„**Contractor**“ means the party designated as the contractor under a public procurement contract in accordance with decision 47/17.05.2016 on the ranking of tenders and selection of a contractor by the Contracting Entity, and which is engaged by the Contracting Entity to deliver Goods including its legal and private successors.

„**Intellectual property**“ means copyright and all rights granted under any law or regulation or any other binding act in respect of inventions (including patents) registered and unregistered trademarks, registered and unregistered designs, schemes and confidential information, and all other rights resulting from intellectual activity in the industrial, scientific, literary or artistic fields.

„**Required Approvals**“ means all permits, licenses, permissions, consents, approvals and certificates (whether by law or not) which are necessary to meet any of the obligations of the Contractor under this Contract pursuant to the law or as a result of third party rights.

„**Unforeseen circumstances**“ means circumstances that have arisen after the conclusion of the Contract and are not the result of an act or omission of the Parties, which could not have been foreseen through due care and which renders execution of the agreed terms impossible.

„**Total Contract price**“ or „**Price**“ means the price of this contract agreed to be paid by the Contracting Entity to the Contractor under the Contract in accordance with the terms hereof and their respective amendments (if any).

„**Site of the Contracting Entity**“ means TPP "AES Galabovo" located at the address of the Contracting Entity.

„**Subcontractor/s**“ means the person or persons specified in the tender of the Contractor as a subcontractor, or any person, whom the Contractor has assigned to deliver part of the Goods as a subcontractor in accordance with the provisions of the Public Procurement Act.

„**Purchase Order**“ or „**Order**“ means a delivery order set to the Contractor with a Purchase Order Form. „**Business Day**“ means any day other than Saturday, Sunday and a public holiday.

„**Payment timeframe**“ means the period indicated in Article 3.3 hereof, unless a longer period has been specified in the offer the Contractor. In this case, the period specified in the offer shall apply.

„**Goods**“ means all Goods to be delivered under this contract together with all accessories and/or services accompanying their delivery according to technical specification of the Contracting Entity.

„**Technical specification**“ means a technical specification and conditions of the Contracting Entity, which is an attachment to and an integral part of the Contract.

„**Force majeure**“ means fire, explosion, earthquake, extremely harsh weather conditions, war, hostilities, rebellion, revolution, insurrection, military or usurping power, civil war, terrorist attack, events caused by aircraft or objects dropped by them, civil unrest, riots, government actions, unexpected or unforeseen at the date of this contract, or any combination of the

above factors insofar as these are beyond the reasonable control of a Party and prevent the Party from meeting its obligations arising from this contract. "Force majeure" will also be considered any circumstances constituting force majeure within the meaning of Art. 306 of the Commercial Act.

The headings herein shall only be indicative.

2. Subject of the Contract

The Contracting Entity assigns and the Contractor agrees against the price mentioned hereunder to transfer ownership and deliver to the Contracting Entity the Goods specified in the Special Conditions (Appendix 1), the Technical Specification (Appendix 2), the Proposal for Public Procurement Order Execution, (Appendix 3), the Offered Price (Appendix 4) and the public procurement implementation conditions, which are an integral part of this contract, subject to the agreed terms and conditions.

3. Goods price and payment

- 3.1. The price of the Goods is the amount specified in the Special Conditions (Appendix 1). This price is the final and maximum price payable by the Contracting Entity for the entire duration of this Contract and subject to adjustment only in the cases expressly provided for in the Public Procurement Act.
- 3.2. The price under Article 3.1 includes all costs of the Contractor, including transportation costs for delivery and installation (if applicable) of the Goods to the site of the Contracting Entity or the Contracting Entity's warehouse located at the address specified in the Special Conditions (Appendix 1).
- 3.3. The Contracting Entity will pay the price to the Contractor within thirty (30) days from the delivery date and the cumulative fulfillment of the following conditions:
 - (a) The Contractor shall submit the original of a tax invoice in accordance with the requirements of the Accounting Act; and
 - (b) The Contractor shall submit all required documents related to the Goods (where applicable) listed in tender documentation, such as, but not limited to certificates of quality, instructions for operation, installation and dismantling of the Goods, warranty and/or service book and/or any other documents related to the type of Goods and the requirements in the technical specification; and
 - (c) an inspection of the Goods performed by the Contracting Entity; and
 - (d) an acceptance certificate signed by both Parties after inspection and acceptance of the Goods without any objections, including at least the following information (date on which the Goods have been delivered, type of Goods, quantity of Goods, related documentation); and
 - (e) before the final payment to be made by the Contracting Entity, the Contractor shall provide evidence that the Contractor has paid to the subcontractor/subcontractors all due amounts in connection with the performance of this Contract in the event that the Contractor has mentioned in his tender that the Contractor will use and has used subcontractors.

- 3.4. All payments under this Contract shall only be made by bank transfer/s to an account of the Contractor specified in the Special Conditions (Appendix 1).
- 3.5. The Contractor shall immediately notify the Contracting Entity in writing of any changes in the bank information under clause 3.4. Otherwise, all payments made by the Contracting Entity shall be deemed to have been duly effected.
- 3.6. When Goods are delivered in several lots or pursuant to individual Orders of the Contracting Entity, the provisions of Art. 3.2 through Art. 3.4 shall be applicable to each individual lot or actual delivery.

4. Term of the Contract

Present contract shall be in effect for the period specified in the Special Conditions (Appendix 1).

5. Delivery terms and delivery times

- 5.1. The Contractor shall deliver the Goods to the Contracting Entity in the manner specified in the Special Conditions (Appendix 1).
- 5.2. The Contractor shall deliver the Goods to the Contracting Entity at the address specified in the Special Conditions (Appendix 1).
- 5.3. If the subject of the Contract is an estimated quantity of Goods or Goods up to a specified maximum quantity, the Contracting Entity shall not be obliged to order the supply of all Goods and the Contracting Entity shall not be liable to pay the price for them.
- 5.4. Regardless of the manner of delivery of the Goods (in full as a single lot, in several lots or pursuant to individual Orders of the Contracting Entity), the Contractor shall notify the Contracting Entity of the delivery and scheduled time in the manner, specified in the Special Conditions (Appendix 1).
- 5.5. Unless otherwise agreed by the Parties in writing, Goods shall only be accepted by the Contracting Entity between 9am and 4pm on working days. If Goods are supplied in lots, the delivery period shall be agreed by the Parties in the Special Conditions.
- 5.6. If the delivery of Goods is performed in lots or pursuant to Orders of the Contracting Entity, the times for such deliveries of Goods shall be indicated in the Special Conditions (Appendix 1) or as specified in the Purchase Order Forms." If the Contractor delivers the Goods in lots or pursuant to Orders of the Contracting Entity, unless otherwise agreed, the Contracting Entity may refuse to accept the quantity of Goods in excess of the quantities included in any lot or Purchase Order. The refusal of the Contracting Entity needs not be motivated but the Parties shall sign a certificate thereof, stating that the Contractor has delivered the Goods in quantities exceeding the contracted quantity.
- 5.7. The Contracting Entity shall send to the Contractor Purchase Orders electronically to an electronic address specified by the Contractor, by post or by courier or in any other manner agreed between the Parties. The Contractor shall confirm receipt of the Purchase Order.
- 5.8. If the Contractor fails to confirm explicitly receipt of a Purchase Order, the purchase order shall be deemed accepted and confirmed by the Contractor on the date on which the P has sent it.

- 5.9. The persons who shall represent the Contractor upon delivery of Goods shall be listed in the key personnel of the Special Conditions (Appendix 1).
- 5.10 The persons mentioned in the preceding clause can be changed by the Contractor, and the Contractor shall notify the Contracting Entity in advance in writing of such a change within five (5) days prior to delivery and acceptance of the Goods.

6. Rights of the Contracting Entity

- 6.1 The Contracting Entity has the right to receive the Goods against the contract price in accordance with the terms and conditions hereof.
- 6.2. The Contracting Entity shall be entitled to perform inspections to the Goods at each stage of implementation of this contract concerning quality, quantity, technical parameters, to make sure that the Goods are in compliance with the Technical Specification (Appendix 2) and the Proposal for Public Procurement Order Execution (Appendix 3), which are an integral part hereof.
- 6.3. If the Goods do not meet the Technical Specification (Appendix 2) and/or the Proposal for Public Procurement Order Execution (Appendix 3), the Contracting Entity may refuse to accept the Goods referring to Article 12.
- 6.4. If the Contracting Entity refuses to accept any Goods, the Contracting Entity shall not be liable to pay the Price or the relevant part of it.
- 6.5. The Contracting Entity may ask the Contractor to enter into a Subcontract with the Subcontractor/s mentioned in the tender of the Contractor (if the Proposal for Public Procurement Order Execution (Appendix 3) and the terms and conditions for fulfillment of the public procurement provide for it).
- 6.6. If the Contractor has provided a Performance Guarantee under this Contract, the Contracting Entity may retain or forfeit the entire Performance Guarantee or part of it provided that the Contractor has failed to fulfill in full or in part any of the provisions hereof.
- 6.7. The Contracting Entity requires from the Contractor, its employees, representatives, and its Subcontractors (if applicable) to comply with the access rules for third parties to the site of the Contracting Entity as well as to meet the requirements and obligations related to health and safety of the workers and the life and health of any other persons on the site of TPP AES Galabovo.

7. Obligations of the Contracting Entity

- 7.1. The Contracting Entity shall pay the Contractor the price of Goods supplied under the terms and conditions hereof.
- 7.2. The Contracting Entity shall render the necessary assistance to the Contractor related to the execution of this Contract and following a request in writing by the Contractor, the Contracting Entity shall provide the Contractor with any information required for that purpose.
- 7.3. Unless otherwise agreed, the Contracting Entity shall provide to the Contractor access to the place of delivery after obtaining the permits for such access, where these are required by the binding provisions.

8. The Contractor shall be entitled:

- 8.1. To obtain the Price for delivery of the Goods after their acceptance and approval without comments by the Contracting Entity under the terms and within the timeframes specified herein;
- 8.2. To obtain from the Contracting Entity the information that the Contractor needs for fulfillment of its obligations under this Contract. The request for information shall be submitted in writing.

9. The Contractor undertakes:

- 9.1. To transfer ownership of the Goods to the Contracting Entity and to deliver the Goods according to the agreed terms and timeframes;
- 9.2. To deliver to the Contracting Entity Goods of type, quality, quantity and technical data in accordance with the Technical Specification (Appendix 2) and the other requirements for delivery fulfillment;
- 9.3. To deliver the Goods to the Contracting Entity in the manner specified by the Contracting Entity - in full as a single lot, in several lots or pursuant to individual orders of the Contracting Entity;
- 9.4. To notify the Contracting Entity of the delivery in advance in accordance with the terms and conditions specified in Article 5 hereof;
- 9.5. If applicable, to deliver the Goods to the place of delivery within one working day;
- 9.6. If applicable, to ensure the presence of its representative/s and representatives of its Subcontractor/s during acceptance of the Goods;
- 9.7. To notify the Contracting Entity in writing as soon as possible in case it is unable to deliver the Goods in accordance with the Technical Specification (Appendix 2), the terms of completion, the agreed or ordered quantities or the delivery date;
- 9.8. To remedy at its expense by replacing or otherwise all defects, faults, errors or omissions in the Goods that might occur within the warranty period offered by the Contractor;
- 9.9. To respect and fulfill the requirements and obligations related to ensuring health and safety of the employees at the site of the Contracting Entity, and to protect the life and health of third parties at the site of TPP AES Galabovo;
- 9.10. To fulfill its obligations under this Contract with due diligence;
- 9.11. To perform its duties under this Contract without disturbing the activities of any staff and other persons working close to the site of the Contracting Entity;
- 9.12. To observe and comply with the conditions of access for third parties at the site of TPP AES Galabovo.

10. Ordering procedure

Where applicable, the Contracting Entity will send Purchase Orders/s to the Contractor.

11. Contractor warranties

- 11.1. The Contractor shall guarantee that the delivered Goods:

- (a) will be in full compliance with the Technical Specification (Appendix 2), the Proposal for Public Procurement Order Execution (Appendix 3) and the Offered Price (Appendix 4) of the Contractor;
- (b) will meet the quality requirements and will be fit for the intended purpose;
- (c) will comply with the relevant binding regulations;

And also that for each delivery the Contractor shall apply the necessary professional experience and diligence that may reasonably be expected by a qualified and competent supplier with experience in carrying out similar supplies of similar size, scope, nature, value and complexity, and that it will invest sufficient resources for the full implementation of its obligations

11.2. The Contractor shall ensure that no third parties shall have ownership rights or any other rights or claims in respect of the Goods.

11.3. Without limitation to the provisions under clauses 11.1 and 11.2, the Contractor shall ensure that:

- (a) it will complete each delivery of Goods by the relevant delivery date;
- (b) it will always perform delivery of Goods with due diligence;
- (c) It will provide all the manpower it will ensure that all the staff employed in the delivery the Goods is qualified, trained and experienced for such delivery;
- (d) it will make delivery of Goods in full compliance with applicable legal requirements, technical specifications and requirements, which are an integral part hereof and also it will provide all necessary approvals;
- (e) it will comply with all reasonable instructions given by the Contracting Entity in connection with the delivery of the Goods;
- (f) it will fulfill the procedures and requirements of the Contracting Entity for health, safety and environmental protection introduced at the site of the Contracting Entity and it will take all necessary precautions to protect the health and safety of all persons, including its own staff, the staff of the Contracting Entity and of TPP AES Galabovo as well as the population that may be affected by the actions of the Contractor while performing delivery of Goods;

11.4. The Contracting Entity may remove the Contractor from the site of the Contracting Entity if the Contractor violates the health and safety requirements established at the site of the Contracting Entity.

11.5. The guarantee period (if applicable) for the completed delivery shall be the period specified in the Special Conditions (Appendix 1).

12. Terms and conditions for delivery and acceptance of the Goods. Claims.

12.1. Unless otherwise agreed, handover and takeover of Goods shall be done by persons designated by the Parties within the working day at the agreed place of delivery.

12.2. If applicable, acceptance of the Goods shall be certified by signing an acceptance certificate. The acceptance certificate shall serve as certification of the delivery date and the quantity of Goods delivered, quantity discrepancies, missing items, damaged packaging, incomplete documents accompanying the Goods and other comments in respect of the Goods.

In respect of Goods not covered by a guarantee period, the Contracting Entity may make claims for hidden defects, faults and non-conformity of the Goods within 60 (sixty) days from the date of delivery acceptance.

- 12.3. If during inspection of the Goods the Contracting Entity identifies any faults, defects and/or any other discrepancies of the Goods with regard to the Technical Specification (Appendix 2) and/or the Proposal for Public Procurement Order Execution (Appendix 3), the Contracting Entity shall within the period specified under Article 12.2 notify in writing (including electronically to an e-mail address specified by the Contractor) the Contractor of any such faults, defects and/or discrepancies.
- 12.4. In the cases under the preceding clause, the Contracting Entity may return the Goods to the Contractor at the expense of the latter. If the Contracting Entity is interested in the delivery of Goods on a later date, the Contracting Entity may ask the Contractor to replace the Goods and/or remove any identified faults, defects and/or discrepancies at the expense of the Contractor within a time frame instructed by the Contracting Entity. If the delivered Goods do not comply with the Specification with regard to quality and that has been established and duly documented by representatives of the Contracting Entity within the guarantee period of the Goods or within the time frame specified in clause 12.2, the Contracting Entity may order the production and delivery of such Goods to another supplier and then the Contractor must pay all costs incurred by the Contracting Entity for the production and delivery of the Goods.
- 12.5. For deliveries of replaced Goods and/or Goods with removed faults, defects and/or discrepancies, the Parties shall apply the above mentioned terms and conditions for delivery and acceptance of Goods.
- 12.6. If the Contractor has offered more favorable conditions for Goods acceptance and claims, such provisions in the tender of the Contractor shall prevail over the provisions hereof.

13. Performance Guarantee. Terms and conditions for Performance Guarantee release and retention

- 13.1. If the contractor has provided the Contracting Entity with a Performance Guarantee under this contract, the Contracting Entity may retain the Performance Guarantee until the Contractor executes completely, accurately and entirely this contract or until expiry of the guarantee period of the Goods.
- 13.2. The Performance Guarantee provided under this Contract shall be equal to the price of the Goods, specified in the Special Conditions (Appendix 1) and shall be in the form of irrevocable and unconditional bank guarantee payable at first written demand by the Contracting Entity or in the form of cash deposit into a bank account of the Contracting Entity. When it is a bank guarantee, the Performance Guarantee shall be valid 1 (one) month after expiry of the guarantee period of the Goods.
- 13.3. The Contracting Entity may retain or forfeit the Performance Guarantee if the Contractor fails to perform any of its obligations under this Contract, including, but not limited to late fulfillment of its obligation to deliver the Goods by more than 7 (seven) days, unless otherwise agreed.
- 13.4. The Contracting Entity may retain and forfeit the Performance Guarantee under this Contract without waiving its right to claim compensation for damage incurred in excess of the amount provided as Performance Guarantee by the Contractor.
- 13.5. Upon proper execution of this Contract by the Contractor, the Contracting Entity shall release the bond under clause 13.2 within one month from the completion date of the Contract (if the bond is in the form of a cash deposit), unless otherwise agreed.

- 13.6. The Contracting Entity may retain part of the Performance Guarantee (if it is a cash deposit) to secure the obligation for warranty servicing of the Goods if the Contractor has undertaken by this contract and/or by its offer to provide warranty service to the delivered Goods.
- 13.7. In the event of a dispute arising between the Parties during the execution of this contract related to a breach of the obligations made by the Contractor, the Contracting Entity may retain the Performance Guarantee (if it is a cash deposit) or may ask the Contractor to extend the validity of the issued bank guarantee until final resolution of the dispute by the competent court under this contract or by an arbitration court.
- 13.8. If this Contract is terminated or cancelled due to the Contractor's fault, the Contracting Entity may retain or forfeit the full amount of the Performance Guarantee.
- 13.9. The Contracting Entity shall not owe interest to the Contractor on the Performance Guarantee (if it is a cash deposit) for the period when the Contracting Entity has lawfully retained it.

14. Penalties and sanctions

- 14.1. If delivery is made after the date of delivery, the Contractor shall pay a penalty of 0.1% (zero point one percent) of the value of the Goods delivered late for each day of delay but not more than 8% (eight percent) of the price of Goods without VAT
- 14.2. If the Contracting Entity terminates the contract due to the Contractor's fault, the Contractor shall pay a penalty of 8% of the price of Goods without VAT. The Contracting Entity shall also be entitled to compensation under the general procedure for actually suffered loss in excess of the penalty amount.
- 14.3. In case of late payment, the Contracting Entity shall pay a penalty of 0.1% (zero point one percent) of the value of the delayed payment for each day of delay but not more than 8% (eight percent) of the value of the payment due.

15. Contract Amendment

Amendment of this Agreement shall be allowed as an exception and it shall be done by an additional agreement in writing mutually agreed between Parties in case of any precondition expressly provided for in the Public Procurement Act.

16. Invoicing

- 16.1 The Contractor shall issue a tax invoice bearing the number of this contract, the order number, if applicable, containing the particulars required by the Accounting Act, and accompanied by the supporting information required under the Contract or by the Contracting Entity. Invoices shall be prepared and accepted under the procedure for sending and accepting of invoices (Appendix 6). If the provisions of clause 3.3 hereof are fully and precisely fulfilled, the Contracting Entity shall pay the amount indicated in the invoice within the specified payment period.
- 16.2. If the Contractor makes a wrong payment to the Contractor including wrongly charged VAT, the Contractor shall immediately reimburse that amount to the Contracting Entity.
- 16.3. Payments by the Contracting Entity under this Contract are not subject to tax, except VAT and deductions provided by law. In particular, if any payment under this Contract is subject to

withholding tax at source, the Contracting Entity shall withhold the tax from the payment amount and pay it to the account of the National Revenue Agency. In these circumstances, payments to the Contractor will represent amounts due under this Contract, reduced by the withholding tax under the law. It is the duty of the Contractor to prove the reasons for not withholding tax at source.

17. Assignment

- 17.1 The Contractor shall not, without the prior written consent of the Contracting Entity, transfer or otherwise dispose of its rights under this Contract.
- 17.2 In the case of any subcontractors involved in performance of the subject matter of the contract, the Contractor and the subcontractor shall comply with all applicable provisions of the Public Procurement Act. The Contractor shall promptly provide the Contracting Entity with all documents and information on the subcontracts in accordance with the Public Procurement Act.
- 17.3 Contractor shall be responsible to ensure quality of the work and observance of the safety requirements by the staff of its subcontractors. The Contractor shall designate competent persons to supervise the performance of the subcontractors.
- 17.4 The Contractor shall be entitled to make inspections and checks to the work on site and make audits to subcontractors following the procedure by which they are carried to the Contractor.

18. Ownership

- 18.1. Subject to Article 18.3 and in view of the specific conditions of each delivery and passing the risk specified herein, ownership of Goods shall pass from the Contractor to the Contracting Entity at the time of delivery or payment by the Contracting Entity (if for some reason payment precedes delivery).
- 18.2. Subject to Article 18.3 and in view of the specific conditions of delivery and passing the risk specified herein when the Contractor receives Goods from a third party, the Contractor shall ensure that ownership of the Goods is transferred to the Contracting Entity at the time of delivery or payment by the Contracting Entity (if for some reason payment precedes delivery).
- 18.3. If payment is made by the Contracting Entity before delivery, and in view of the specific conditions of delivery and passing the risk specified herein, ownership of the Goods shall be transferred by the Contractor to the Contracting Entity as soon as Goods can be identified, but the risk of loss or damage shall not pass onto the Contracting Entity before the time of delivery. Such advance payment shall not be construed as meaning that the Goods have been approved by the Contracting Entity.

19. Intellectual property licenses and confidentiality

- 19.1. The Contractor shall ensure that delivery and use of the Goods will not break any patent, registered design, copyright, trademark or other intellectual property rights ("**Protected Rights**"). Unless the Contracting Entity has agreed otherwise, the Contractor shall provide to the Contracting Entity an irrevocable, royalty-free non-exclusive license for such use from third parties when such is necessary for making full use of the Goods and their features.
- 19.2. The Contractor shall indemnify the Contracting Entity in case that the Contracting Entity is held liable for violation of any protected rights in connection with the use of the Goods.

- 19.3. The Contractor shall keep all the information and software related in any way with the Contracting Entity, as most strictly confidential and the Contractor shall not to use or disclose them except for the purposes hereof, without the prior written consent of a person authorized by the Contracting Entity.
- 19.4. If any specific conditions under this Contract arise, the Contractor shall immediately obtain all necessary permits for import and export and all other approvals required for the delivery of Goods.

20. Risk, liability and insurance

- 20.1. The Contractor shall indemnify the Contracting Entity for all damages related to loss or damage to property of the Contracting Entity or third party, as well as costs for removing spills of chemical substances and mixtures, including adverse environmental footprint impacts of them arising out of or in connection with fulfillment or non-fulfillment of the obligations of the Contractor under this Contract, unless such a liability arises out of or in connection with intentional acts or gross negligence on the part of the Contracting Entity or its representatives.
- 20.2. The Contractor shall indemnify the Contracting Entity for all direct costs and claims (including for loss of or damage to property and injury or death of a person) suffered by the Contracting Entity as a result of violation hereof or any other infringement action or omission (including negligence) of the Contractor or a person for whom the Contractor bears responsibility.
- 20.3. Contractor shall be liable for any loss or damage to the Goods until their delivery to the Contracting Entity, except in the cases where this Contract provides for passing of the risk otherwise. The Contractor shall be liable for any loss or damage to the Goods during the whole period of time (e.g. their stay in the warehouse of the Contractor or within the guarantee period during which the Contractor shall take care of the Goods and check them.
- 20.4. The Contractor shall (if applicable and if provided in the Technical Specifications (Appendix 2) and the conditions for public procurement execution) provide and/or arrange the obtaining of appropriate insurance for the period of performance of its obligations under the Contract within its scope at commercially acceptable conditions, including insurance of the Contractor's staff, namely employer's liability insurance required by law, and insurance against earthquake, flood, force majeure and fire. In these cases, the Contractor shall conclude and maintain insurance policies with a financially stable insurer with proper reputation approved by the Contracting Entity, and under conditions acceptable for the Contracting Entity, so as:
- (a) To insure the Goods appropriately and adequately against loss or damage from the date of this Contract until delivery; and
 - (b) To cover injuries, disability or other professional risks to the Contractor's staff.

Where applicable, the insurance maintained by the Contractor shall include provisions for subrogation in favor of the Contracting Entity and it shall also provide for the Contracting Entity as an additional beneficiary.

- 20.5. The Contractor shall (if applicable and if provided in the Technical Specifications (Appendix 2) and the conditions for public procurement execution) maintained for the period necessary to meet its responsibilities under this Contract, insurance for damage caused by the Goods provided by Contractor with insurance coverage sufficient to cover the liability (and in any case the amount of the minimum percentage of the total price of the order, specified in the Special conditions (Appendix 1)) with an insurer and on terms acceptable

for the Contracting Entity. The Contractor shall, upon request by the Contracting Entity, provide appropriate proof for the fulfillment of this Article. 20.5.

- 20.6. The Contractor shall promptly and with due care require payment of compensation under the respective policies in accordance with Article 20.4 above and shall repay the obtained money to the Contracting Entity.
- 20.7. If the Contractor fails to conclude or maintain the insurance required under the terms hereof or according to the terms under which the contract has been awarded, the Contracting Entity shall have the right but not the obligation to provide and maintain such a policy solely and entirely at the expense of Contractor. In this case, the Contracting Entity shall be entitled to reimbursement of reasonable expenses directly incurred in connection with the policy or to deduction of these expenses from the amounts payable to the Contractor.
- 20.8. The Contracting Entity shall not be responsible for the damage and loss of plant, materials and equipment of the Contractor and the risk for them shall be borne by the Contractor.
- 20.9. The Contractor shall carry out any activity on the site of the Contracting Entity in a way that does not upset and disturb the neighbors of the site. In particular, while located on the site of the Contracting Entity, the Contractor must comply and ensure that its employees, officers, agents and subcontractor/s observe:
- (a) all binding provisions and requirements of government or any other authority having jurisdiction over the site of the Contracting Entity in relation to access to the site, health, safety and environmental protection; and
 - (b) health requirements, requirements and procedures on safety and environmental protection of the Contracting Entity.
- 20.10. The Contractor agrees and hereby accepts full and sole responsibility for withholding and paying any and all taxes, contributions, etc., to which it and its Subcontractors are subject to tax with respect the Unemployment Fund and also the contributions towards social, pensions insurance, pensions and the like, imposed by the existing and any future regulations of the authorities in terms of wages, salary or other remuneration payable to the staff employed by the Contractor and its Subcontractors in connection with the delivery of the Goods and other contractual work.
- 20.11. Persons, for whom the Contractor is responsible, including its employees, officers, representatives, consultants, subcontractors and sub-suppliers of each of them.
- 20.12. Nothing herein (express or implied) does not limit the liability of the Contractor in the performance of its obligations under this Contract.

21. Terms and conditions for termination / cancellation of the contract

21.1. This Contracts terminates:

- (a) upon expiry of the term under Article 4 of the Contract;
- (b) upon its final completion;
- (c) by mutual agreement of the Parties expressed in writing;
- (d) unilaterally by the Contracting Entity at any time by sending ten (10) days written notice to the Contractor specifying whether the contract will be terminated partially or entirely and the date on which the termination will take effect;

- (e) by the Contracting Entity upon occurrence of an unforeseen event mentioned in Article 43, para. 4 of PPA, making it impossible for the Contracting Entity to fulfill its obligations under the Contract;
- (f) upon any transformation of the Contractor in accordance with the law of the country, in which it has been established in the event that its successor does not meet the conditions laid down in the Public Procurement Act for continuation of the procurement contract;
- (g) in case of any other grounds for termination of the procurement contract provided for in the Public Procurement Act.

21.2. The Contracting Entity may unilaterally terminate the contract without notice if the Contractor:

- (a) delays the execution of any of its obligations under this Contract for more than 7 (seven) days;
- (b) refuses to replace the Goods showing faults, defects and discrepancies within the time specified by the Contracting Entity;
- (c) refuses to remedy at its expense faults, defects and discrepancies identified in the delivered Goods within the time frame specified by the Contracting Entity;
- (d) fails to fulfill accurately and in full compliance any of its obligations under this Contract and its appendices;
- (e) uses Subcontractor/s for execution of this Contract without declaring this fact in its tender or uses Subcontractor/s which is/are not mentioned in its proposal unless expressly permitted by PPA;
- (e) in case of insolvency proceedings initiated against the Contractor or termination of its commercial activity due to liquidation under the national law of the country in which the Contractor is registered.

21.3. The Contractor shall not be entitled to compensation or offset for expenses incurred or arising after Contract termination, save for costs resulting directly and immediately from the termination of delivery, if the Contracting Entity has given its prior written consent for incurrence of such expenses.

21.4. In case of termination of the delivery or any part of it, the Contractor shall provide to the Contracting Entity all documents related to the assigned delivery or part thereof.

22. Non-exclusivity

Nothing herein shall be construed as prohibiting the Contractor or the Contracting Entity from entering into similar contracts or other agreements with any other companies, partners or parties.

23. Severability

All provisions herein are separate and different from one another and if for some reason one or more of these provisions are rendered invalid or unenforceable, it shall be deemed to be isolated and deleted from this Contract, in which case the other provisions of the Contract shall remain in full effect.

24. Notices

All notices delivered in connection with this Contract shall be in Bulgarian or English and in writing. If there is a discrepancy between the texts in Bulgarian and English, the text in Bulgarian shall prevail and be taken into account. Notices can be delivered in person to the contact persons by e-mail or by mail with return receipt to the address specified herein unless such an address has been changed, for which the relevant Party has informed the other one.

25. Entire agreement

This Contract contains all the issues on which the Parties have agreed and reached understanding on the subject matter of this Contract and supersedes any and all prior negotiations, obligations and correspondence in connection with the subject matter of this Contract, unless the applicable law provides otherwise

26. Governing law and disputes

This Contract shall be governed by the Bulgarian law. All disputes arising out of this Contract or related to it, including those involving or relating to its interpretation, invalidity, performance or termination, as well as disputes about filling gaps in this Contract or its adaptation to new circumstances, shall be referred for resolution to the Arbitration Court at the Bulgarian Chamber of Commerce in accordance with Dispute Board Rules based on arbitration agreements.

Appendixes:

1. Special Conditions;
2. Technical Specification;
3. Proposal for Public Procurement Order Execution ;
4. Offered Price;
5. Agreement for ensuring healthy and safe working conditions;
6. Procedure for sending and accepting of invoices.

Signed for and on behalf of **AES – 3 C Maritza East I EOOD**

Signature: _____

Name: Todor Belezhkov

Title: Plant Manager AES Bulgaria

Signed for and on behalf of **Diamond Power Central & Eastern Europe s.r.o.**

Signature: _____

Name: Juha Mustonen

Title: Managing Director of headquarters at Prague

Diamond Power
Central & Eastern Europe
a Diamond Power International, Inc. company
Phone: +420 543 213 706 Fax: +420 543 213 706
Barvičova 685/41, 602 00 Brno, The Czech Republic
www.diamondpower-cee.com IČ: 283 99 641

Handwritten initials in blue ink.

Appendix 1
Special Conditions

Contracting Entity	AES – 3 C Maritza East I EOOD UIC: 123533834; VAT number: BG123533834
Contracting Entity's address	Galabovo 6280, Galabovo Municipality, Stara Zagora region, Bulgaria
Contracting Entity's Representative	Name: Milen Stoyanov Telephone number: +359 884 377622 E-mail: milen.stoyanov@aes.com
Contracting Entity's Key Personnel	1. Technical matters: Name: Anton Dimov Telephone number: +359 885 263508 E-mail: anton.dimov@aes.com 2. Accounting matters (invoices): E-mail: emea.apinvoices@aes.com 3. Commercial and contract matters: Name: Denitsa Tsoneva Telephone number: +359 42 901 518 E-mail: denitsa.tsoneva@aes.com 4. Health & Safety Coordinator: 24-hours number: 0884 886 663 E-mail: MaritzaEHSTeam@aes.com
Contractor	Diamond Power Central & Eastern Europe s.r.o. UIC: 28399641; VAT No.: CZ28399641.
Contractor's address:	V Jircharich 148/4, 110 00 Praha1, Czech Republic
Contractor's Representative	Name: Juha Mustonen Telephone number: +420 543213705 E-mail: juha.mustonen@diamondpower-cee.com
Subject of Contract	Supply of spare parts for ash disposal system manufactured by Diamond Power
Contractor's Key Personnel	1. Juha Mustonen Telephone number: +420 543213705 E-mail: juha.mustonen@diamondpower-cee.com
Article 3.1 Price of	The Price of Goods - spare parts for ash disposal system

low

/m

Goods	<p>(subject matter of this Contract is as follows:</p> <p>Total price - 37 366,00 Euro, in words (thirty seven thousand three hundred and sixty six Euro), VAT excluded, for DDP delivery on the site of the Contracting Entity as per INCOTERMS 2015.</p> <p>All quantities are tentative. The Contracting Entity will pay only the delivered materials as per the Contract.</p> <p>The Contracting Entity shall pay the price for each delivery within 30 (thirty) days after submission of an invoice original and an acceptance certificate signed without comments by the representative of the Contracting Entity and after meeting the requirements under Article 3.3 of the Contract.</p>
Article 3.4 Bank account indicated by the Contractor	<p>Bank: JPMorgan Chase Bank N.A., Chaseside, Bournemouth, UK, BH7 7DA</p> <p>Account number: 41034467</p> <p>IBAN: GB69CHAS60924241034467</p> <p>SWIFT: CHASGB2L</p> <p>Account name: Diamond Power Central</p>
Article 4 Term of the Contract	<p>The Contract shall come into effect on the date of signature and shall be effective for 6 (six) months.</p>
Article 5.1 Goods Delivery Terms	<p>Delivery of spare parts shall be made once, not later than 9 (nine) weeks from the date of Purchase Order as per the requirements of Technical specification (Appendix 2) and in accordance with the applicable regulations.</p> <p>Each delivery shall be accompanied by:</p> <ul style="list-style-type: none"> (a) Packing List; (b) Acceptance-delivery protocol; (c) Quality certificate and Declaration of conformity issued by manufacturer; (d) Drawing of spare part (if applicable);
Article 5.2 Address for delivery of the Goods	<p>The Goods shall be delivered to the site of the Contracting Entity.</p>
Article 5.4 Way of notification of the delivery date and scheduled time	<p>Notice of readiness for shipment shall be sent to the Contracting Entity at least 1 (one) day prior to the date of shipment to electronic address store@aes.com</p>

Wes:

h

Article 10.5 Guarantee period	The Guarantee period of pos. 2 from the Technical proposal (Appendix 3) is 1 (one) year from the date of delivery.
Article 13.2 Performance Guarantee amount	Not applicable
Article 14 Penalties and Sanctions	In case of delay in the execution of the Contract by more than 3 (three) Working Days, the Contracting Entity shall be entitled to compensation under the general procedure for actually suffered loss in excess of the penalty amount. For actually suffered loss in excess of the penalty amount agreed, the concerned Party may seek compensation in full by arbitration.
Article 20.5 Insurance	Not applicable

WPS.

h

Appendix 2

Technical Specification

Appendix 3

Technical proposal for Public Procurement Order Execution

Appendix 4

Price Offer

WPS

h



Утвърдил:

/Управител Ей И Ес-3С Марица Изток 1 ЕООД /

Дата: 22.02.2016

Изготвил:

Одобрил:

Николай Армянов

Димо Бахов

Милен Стоянов

Антон Димов

ТЕХНИЧЕСКА СПЕЦИФИКАЦИЯ

Наименование:

Доставка на резервни части за системата за пепелоизвозване производство на "Diamond Power"

Документ:

ME1-MP-TRM-0077

Местоположение на документа в Системата за контрол на документи MS Share Point на Ей И Ес Марица

Библиотека:

1.ТЕЦ/5.Инженеринг/11.Технически спецификации

	Документ №: ME1-MP-TRM-0077 ТЕХНИЧЕСКА СПЕЦИФИКАЦИЯ	Дата: 22.02.2016
	Доставка на резервни части за системата за пепелоизвозване производство на "Diamond Power"	Страница: 2/5

Съдържание:

1. ПРЕДМЕТ НА ДОСТАВКАТА	3
2. ТЕХНИЧЕСКИ ИЗИСКВАНИЯ	3
2.1. Технически изисквания към доставката.....	3
2.2. Технически изисквания към изпълнителя	3
3. СРОК	3
4. МЯСТО НА ДОСТАВКА	3
5. ДОСТЪП ДО ЕЛЕКТРОЦЕНТРАЛАТА	3
6. ОПАКОВАНЕ, ПАКЕТИРАНЕ И КОМПЛЕКТОВАНЕ	4
7. ПРИЕМАНЕ НА СТОКИТЕ В СКЛАДА	4
8. ПРОТОКОЛИ И РЕФЕРЕНТНИ ДОКУМЕНТИ ПРИ ДОСТАВКА	4
9. ПРИЛОЖЕНИЯ	5

	Документ №: ME1-MP-TRM-0077 ТЕХНИЧЕСКА СПЕЦИФИКАЦИЯ	Дата: 22.02.2016
	Доставка на резервни части за системата за пепелоизвозване производство на "Diamond Power"	Страница: 3/5

1. ПРЕДМЕТ НА ДОСТАВКАТА

Доставка на резервни части за системата за пепелоизвозване производство на "Diamond Power"

2. ТЕХНИЧЕСКИ ИЗИСКВАНИЯ

2.1. Технически изисквания към доставката

- Обхватът на доставката включва резервни части, посочени в количествената сметка ME1-MP-TRM-0077-A1, която е неразделна част от този документ.
- Всички доставени резервни части, трябва да са оригинални, нови и неупотребявани и да бъдат придружени със Сертификат за качество и Декларация за съответствие от производителя.

2.2. Технически изисквания към изпълнителя

Изпълнителят трябва да предостави:

- Сертификат удостоверяващ съответствието на производителя със стандарт за системи за управление на качеството в област аналогична на поръчката ISO 9001:2008 или еквивалент.

3. СРОК

Доставката на частите от (Приложение 1 – Количествена сметка) да се извърши, до **01.07.2016 година**.

4. МЯСТО НА ДОСТАВКА

Мястото на доставка е ТЕЦ Ей И Ес-3С Марица Изток I се намира в град Гълъбово, на приблизително 50 км югоизточно от град Стара Загора. Резервните части се доставят с транспорт на Изпълнителя до склада, който се намира на територията на централата.

5. ДОСТЪП ДО ЕЛЕКТРОЦЕНТРАЛАТА

Работното време с доставчици на стоки в склад е всеки работен ден от понеделник до петък от 8:30 до 15:00 часа.

Доставчиците трябва да следват следните правила при доставка на стоки:

При доставката, доставчикът представя на входен портал на електроцентралата копие от поръчка за доставка или други документи, удостоверяващи, че стоките се доставят съгласно договор или поръчка на Ей И Ес-3С Марица Изток I ЕООД. Изготвя се временен пропуск от охранител на портала.

Водачите на МПС на територията на централата трябва да се движат, спират и паркират така, че по никакъв начин да не пречат на движението на другите превозни средства (пожарна, линейка, служебни автомобили) или хора.

	Документ №: ME1-MP-TRM-0077 ТЕХНИЧЕСКА СПЕЦИФИКАЦИЯ	Дата: 22.02.2016
	Доставка на резервни части за системата за пепелоизвозване производство на "Diamond Power"	Страница: 4/5

Транспортните средства и техните водачи трябва да отговарят на нормативните изисквания за автомобилен превоз на опасни товари и всички други приложими нормативни актове, регламентиращи дейността по превоз на товари.

Водачите на транспортните средства, трябва да разполагат с лични предпазни средства (ЛПС), които са задължителни на територията на централата: каска, защитни обувки, предпазни очила, подходящо работно облекло, както и с допълнителни ЛПС съгласно Информационния лист за безопасност стоките, които транспортират.

Абсолютно се забранява внасянето на алкохол, наркотици или други психотропни вещества, както и достъпа на територията на централата на лица, употребили такива вещества.

Абсолютно се забранява внасянето на огнестрелно, газово и хладно оръжие, както и на взривоопасни материали.

6. ОПАКОВАНЕ, ПАКЕТИРАНЕ И КОМПЛЕКТОВАНЕ

Доставените резервни части трябва да бъдат в оригинални, с ненарушена цялост, затворени опаковки, които да имат защита до първоначално отваряне и с оригинални етикети на фирмата-производител. Комплектоването на резервните части трябва да бъде според всеки номер по редове от Приложение 1 – Количествена сметка.

7. ПРИЕМАНЕ НА СТОКИТЕ В СКЛАДА

При доставка на стоки Изпълнителят е длъжен за уведоми за датата и часа на доставката един ден преди датата на доставка в склад, с цел да бъде организирана необходимата техника за товаро-разтоварни дейности на стоките.

Всяка доставка трябва да е придружена с уведомление за експедиция (известие).

Всяка първа доставка на дадена резервна част трябва да бъде придружена с всички технически документи, които се предоставят от производителя на тази резервна част, като чертежи, техническа спецификация, артикулни номера, сертификати и други.

В случай че доставката не е придружена от всички необходими документи или има видими несъответствия в съответната заявка за доставка, доставката не се приема.

8. ПРОТОКОЛИ И РЕФЕРЕНТНИ ДОКУМЕНТИ ПРИ ДОСТАВКА

Стоките трябва да бъдат придружени от следните документи:

- Опаковъчен лист;
- Приемо-предавателен протокол;
- Сертификат за качество или Декларация за съответствие от производителя;
- Чертеж на изделието (ако е приложимо);

	Документ №: ME1-MP-TRM-0077 ТЕХНИЧЕСКА СПЕЦИФИКАЦИЯ	Дата: 22.02.2016
	Доставка на резервни части за системата за пепелоизвозване производство на "Diamond Power"	Страница: 5/5

9. ПРИЛОЖЕНИЯ

№	Номер на документа	Наименование
1	ME1-MP-TRM-0077-A1	Количествена сметка
3	F-Q3 REV Y	Техническа документация
4	ASH-PI-017 REV C	Техническа документация
5		

Доставка на резервни части за системата за пепелоизвозване производство на "Diamond Power"

КОЛИЧЕСТВЕНА СМЕТКА

Забележки:						
№	Описание	Мат. Номер	Мерна единица	Количество	Ед.цена BGN	Стойност BGN
1	ASHCOLITE PIPE 10", L=18' Part Number: XF10P		бр.	12		0,00
2	Pneumatic cylinder doc:ASH-PI-017 page.2 position.22 Part Number: 219364		бр.	6		0,00
ОБЩО:						0,00
Забележки:						
1. За коректно попълване на количествената сметка моля попълнете само жълтите полета. 2. Посочените цени да се попълват без ДДС. 3. Посочените количества са ориентировъчни. 4. Точните количества ще се формират на база реални нужди на възложителя. 5. Плащането по договора ще се извърши на база доказани количества.						

F-03

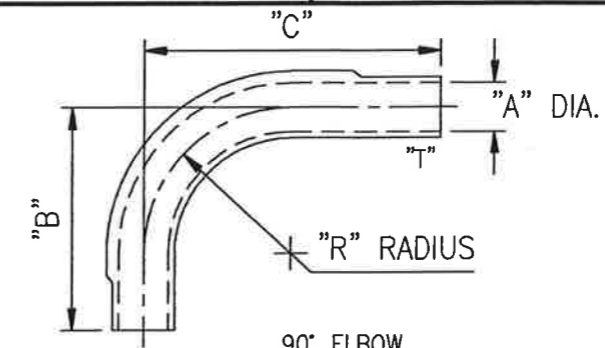

90° ELBOW

PATT. No.	"A"	"B"	"C"	"R"	WT.#
F2.5B	2.323" (59)	15 1/4" (387)	19 3/4" (502)	9" (229)	27
F4B	4" (102)	18 1/4" (464)	2'-0 1/4" (616)	12" (305)	100
F5B	5" (127)	21 1/4" (540)	2'-4 3/4" (730)	15" (381)	155
F6B	6" (152)	2'-0 1/4" (616)	2'-9 1/4" (845)	18" (457)	215
F7B	7" (178)	2'-3 1/4" (692)	3'-1 3/4" (959)	21" (533)	335
F8B	8" (203)	2'-6 1/4" (768)	3'-6 1/4" (1,073)	2'-0" (610)	462
F9B	9" (229)	2'-9 1/4" (845)	3'-10 3/4" (1,187)	2'-3" (686)	560
F10B	10" (254)	3'-2 1/4" (972)	4'-5 1/4" (1,353)	2'-6" (762)	791
F11B	11" (279)	3'-5 1/4" (1,048)	4'-9 3/4" (1,467)	2'-9" (838)	884
F12B	12" (305)	3'-8 1/4" (1,124)	5'-2 1/4" (1,581)	3'-0" (914)	1,250
F14B	14" (356)	4'-2 1/4" (1,276)	5'-11 1/4" (1,810)	3'-6" (1,067)	1,625
F16B	16" (406)	4'-8 1/4" (1,429)	6'-8 1/4" (2,038)	4'-0" (1,219)	2,049
F18B	18" (457)	5'-2 1/4" (1,581)	7'-5 1/4" (2,267)	4'-6" (1,372)	2,934
F20B	20" (508)	5'-10 1/2" (1,791)	8'-2 1/4" (2,496)	5'-0" (1,524)	3,740

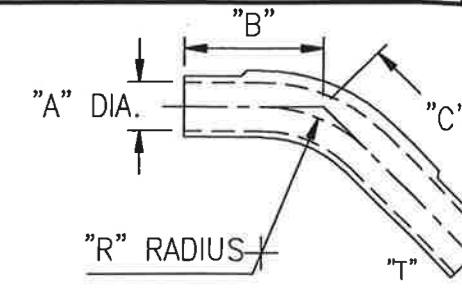

45° ELBOW

PATT. No.	"A"	"B"	"C"
F2.5D	2.323" (59)	10" (254)	14 1/2" (368)
F4D	4" (102)	11 1/4" (286)	17 1/4" (441)
F5D	5" (127)	12 1/2" (318)	20" (508)
F6D	6" (152)	13 11/16" (348)	22 11/16" (579)
F7D	7" (178)	14 15/16" (379)	2'-1 7/16" (521)
F8D	8" (203)	16 3/16" (411)	2'-4 3/16" (582)
F9D	9" (229)	17 7/16" (443)	2'-6 15/16" (651)
F10D	10" (254)	20 11/16" (525)	2'-11 11/16" (707)
F11D	11" (279)	21 15/16" (557)	3'-2 7/16" (788)
F12D	12" (305)	23 3/16" (589)	3'-3 11/16" (820)
F14D	14" (356)	2'-1 5/8" (651)	3'-10 5/8" (945)
F16D	16" (406)	2'-4 5/8" (727)	4'-4 1/8" (1,041)
F18D	18" (457)	2'-6 5/8" (778)	4'-9 5/8" (1,154)
F20D	20" (508)	2'-9 1/8" (841)	5'-3 1/8" (1,267)

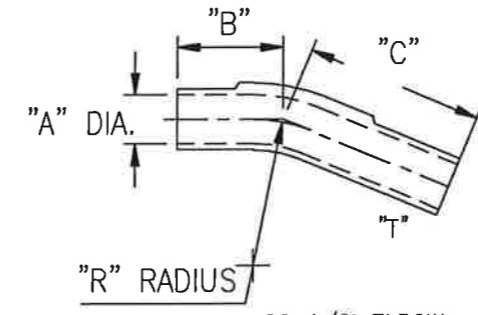

22 1/2° ELBOW

PATT. No.	"A"	"B"	"C"	"R"	WT.#
F4K	4" (102)	8 5/8" (219)	14 5/8" (371)	12" (305)	57
F5K	5" (127)	9 1/4" (235)	16 3/4" (425)	15" (381)	80
F6K	6" (152)	9 13/16" (249)	18 13/16" (478)	18" (457)	113
F7K	7" (178)	10 7/16" (265)	21" (533)	21" (533)	166
F8K	8" (203)	11" (279)	23" (584)	2'-0" (610)	222
F9K	9" (229)	11 5/8" (295)	2'-1 1/8" (638)	2'-3" (686)	270
F10K	10" (254)	14 3/16" (360)	2'-5 3/16" (741)	2'-6" (762)	366
F11K	11" (279)	14 13/16" (376)	2'-7 5/16" (795)	2'-9" (838)	439
F12K	12" (305)	15 7/16" (392)	2'-9 7/16" (849)	3'-0" (914)	580
F14K	14" (356)	16 5/8" (422)	3'-1 5/8" (956)	3'-6" (1,067)	810
F16K	16" (406)	17 13/16" (452)	3'-4 13/16" (1,037)	4'-0" (1,219)	1,150
F18K	18" (457)	19" (483)	3'-10" (1,168)	4'-6" (1,372)	1,380
F20K	20" (508)	20 3/16" (513)	4'-2 3/16" (1,275)	5'-0" (1,524)	1,747

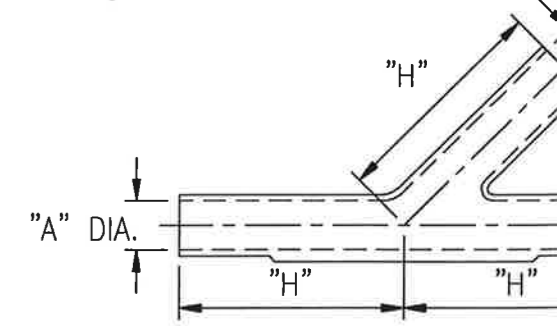

45° LATERAL

PATT. No.	"A"	"H"
F4H	4" (102)	18 1/4" (464)
F5H	5" (127)	19 3/4" (502)
F6H	6" (152)	21 1/4" (540)
F7H	7" (178)	22 1/4" (565)
F8H	8" (203)	23 1/4" (591)
F9H	9" (229)	2'-2 3/4" (679)
F10H	10" (254)	2'-6 1/4" (768)
F11H	11" (279)	2'-7 3/4" (806)
F12H	12" (305)	2'-9 1/4" (845)
F14H	14" (356)	3'-0 1/4" (921)
F16H	16" (406)	3'-3 1/4" (997)
F18H	18" (457)	3'-6 1/4" (1,073)

Y	1-29-10	PMD	LJK	LJK	REVISED PIPE WEIGHTS PER VENDOR INFORMATION	DRAWN BY	WEH	4/7/47
X	1-2-91	BKS			REDRAWN ON CAD & GENERAL REVISION	CHECKED BY		
REV.	DATE	REV. BY	CKD. BY	ENG. APP.	REVISION RECORD	MECH. APP.		
						STRUCT. APP.		
						ELECT. APP.		



THIS DRAWING IS TO BE USED FOR REPAIR AND MAINTENANCE ONLY.

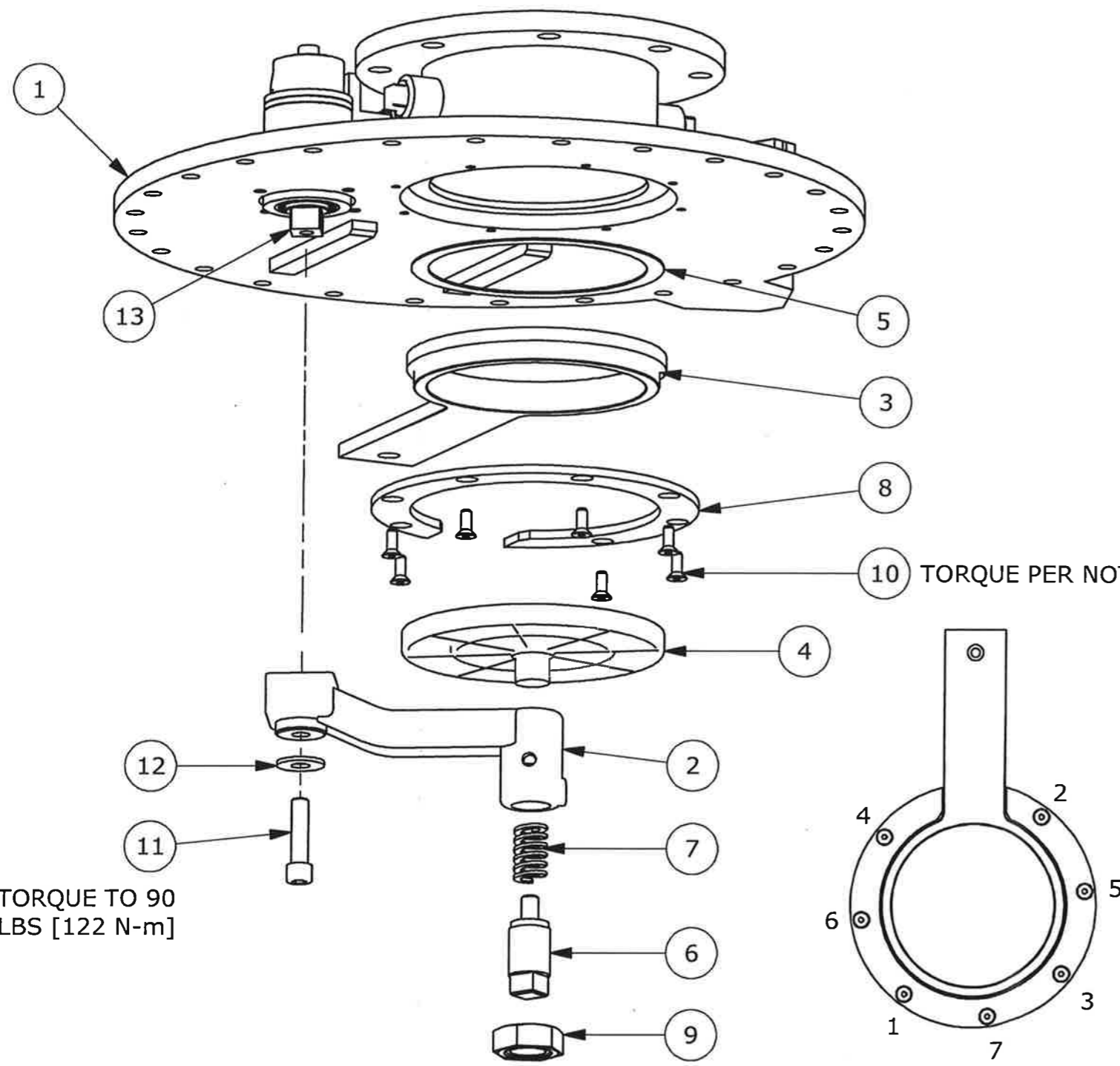

TORQUE TO 90 FT-LBS [122 N-m]

10 TORQUE PER NOTE 2

PARTS LIST			
PART No.	QTY	ITEM NUMBER	DESCRIPTION
1	1	SEE NOTE 1	DECKPLATE
2	1	19144-1	GATE ARM
3	1	19142-1	SEAT
4	1	19141	GATE
5	1	225299	SEAT GASKET
6	1	SEE TABLE 1	SPRING ADJUSTMENT SCREW
7	1	SEE TABLE 1	SPRING
8	1	19143-2	RETAINING RING
9	1	107927	1 1/2-6 JAM NUT
10	7	100813	3/8-16 x 1 FLAT HEAD SOCKET CAP SCREW
11	1	109077	5/8-18 x 2 1/2" SOCKET HEAD CAP SCREW
12	1	101323	5/8" USS PLAIN WASHER
13	1	14429-13	SHAFT

NOTES:

- DECKPLATES VARY DUE TO SEVERAL FACTORS SUCH AS THICKNESS, EQUALIZER VALVE CONNECTIONS, LIMIT SWITCH OPTIONS, AND IF THE VALVE WAS CONVERTED FROM STYLE I TO STYLE IV. SEE YOUR ASSEMBLY DRAWING FOR IDENTIFICATION OF THE DECKPLATE ITEM NUMBER.
- TORQUE FLAT HEAD CAP SCREWS, PART 10, TO 10 FT-LBS [14 N-m] IN SEQUENCE SHOWN. REPEAT SEQUENCE TORQUING TO 16 FT-LBS [22 N-m] AND THEN 23 FT-LBS [31 N-m].

TABLE 1		
TEMPERATURE RATING	SPRING PART No.	ADJUST SCREW PART No.
LOW TEMP (350° F MAX)	109079	19145
HIGH TEMP (750° F MAX)	212843	19145-1

SPRING ADJUSTMENT PROCEDURE

- TURN SPRING ADJUSTMENT SCREW UNTIL GATE CONTACTS SEAT.
 - FOR LOW TEMPERATURE DECKPLATES: TIGHTEN 2 MORE TURNS.
 - FOR LOW TEMPERATURE DECKPLATES WITH ASH HEADS GREATER THAN 15 FT OR EQUALIZER HEADER TO DISCHARGE LINE DIFFERENTIAL PRESSURES GREATER THAN 2.5 PSI: TIGHTEN 3 MORE TURNS.
 - FOR HIGH TEMPERATURE DECKPLATES: TIGHTEN 1.5 MORE TURNS.
- LOCK ADJUSTMENT SCREW IN PLACE BY TIGHTENING JAM NUT.

REV	DATE	REV BY	CKD BY	ENG APP	REVISION RECORD
C	9/28/2011	PAG	DBH		ADD TORQUE SPEC FOR PARTS 10 & 26
B	10/21/2010	PAG	CMH		BUSHINGS, PART #23, WERE INVERTED
A	12/23/2008	PAG			PART #5 WAS 19355-1

DRAWN BY PAG 12/19/2007
 CHECKED BY CMH 1/8/2008
 APPROVED BY

Allen-Sherman-Hoff
 a Division of Diamond Power International, Inc.
 EXTON, PENNSYLVANIA, U.S.A.

© 2010 DIAMOND POWER INTERNATIONAL, INC. ALL RIGHTS RESERVED. THIS DRAWING IS THE PROPERTY OF DIAMOND POWER INTERNATIONAL, INC. (DPII) AND ITS USE IS GOVERNED BY THE TERMS AND CONDITIONS OF THE CONTRACT FOR WHICH IT WAS CREATED. DPII GRANTS A NON-EXCLUSIVE LICENSE TO USE, REPRODUCE AND DISTRIBUTE THIS DRAWING SOLELY FOR THE MAINTENANCE, REPAIR AND OPERATION, AND FOR SOLICITING BIDS FOR THE ERECTION OF, THE EQUIPMENT DISCLOSED HEREIN.

STYLE IV AIRLOCK DECK PLATE

PARTS IDENTIFICATION SHEET

CONTRACT STD
 DWG ASH-PI-017
 REV C
 SCALE: NONE SHEET 1 OF 2

APPLY LOCTITE TO THREADS
TORQUE TO 38 FT-LBS [52 N-m]

OPEN SIDE OF LIP SEALS
SHOULD POINT DOWN

B
W
A

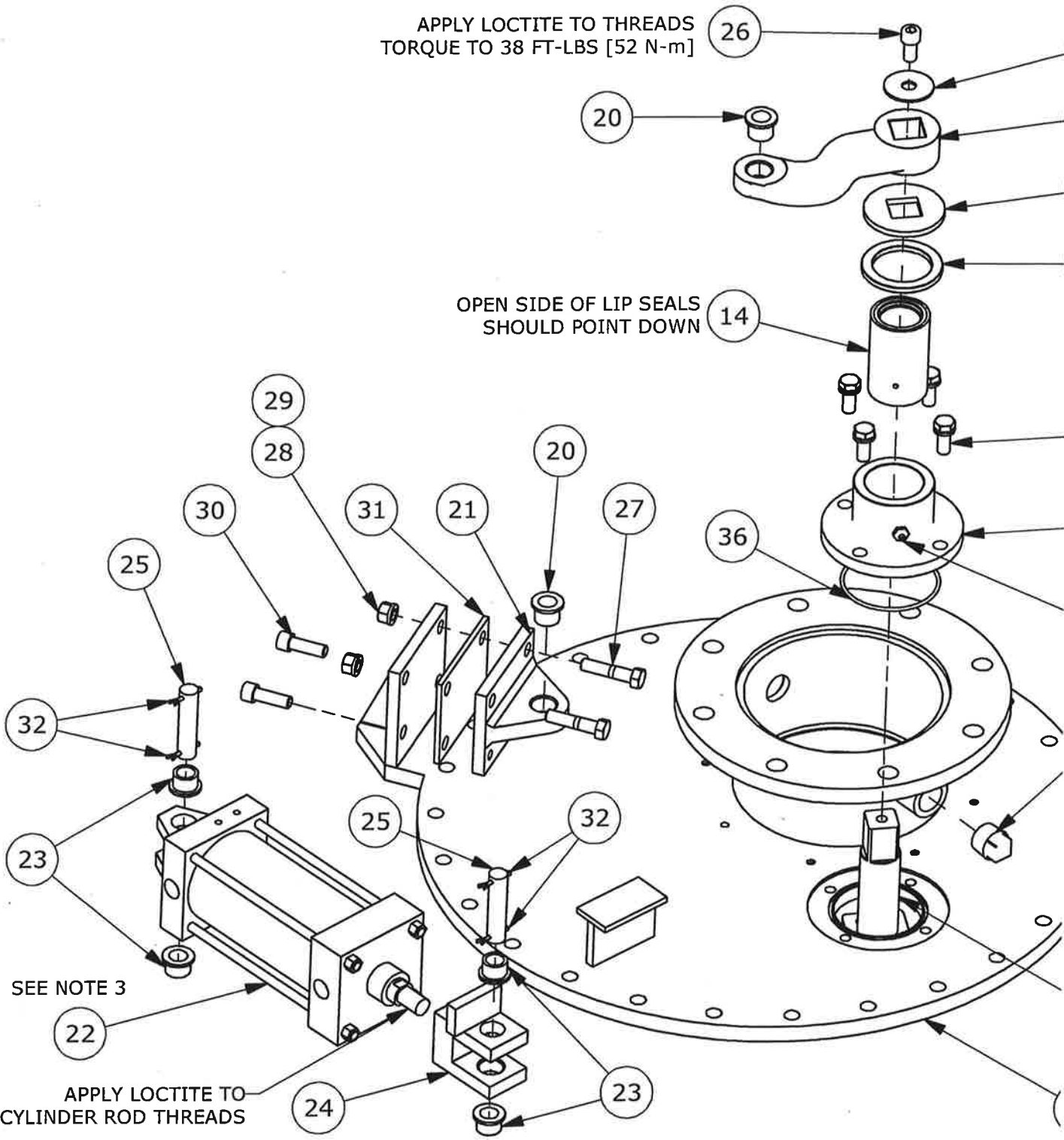

SEE NOTE 3

APPLY LOCTITE TO
CYLINDER ROD THREADS

						DRAWN BY	PAG	12/19/2007
						CHECKED BY	CMH	1/8/2008
C	9/28/2011	PAG	DBH		ADD TORQUE SPEC FOR PARTS 10 & 26	APPROVED BY		
B	10/21/2010	PAG	CMH		BUSHINGS, PART #23, WERE INVERTED			
A	12/23/2008	PAG			PART #5 WAS 19355-1			
REV	DATE	REV BY	CKD BY	ENG APP	REVISION RECORD			



Customer:

AES-3C Maritza East I EOOD
Galabovo 6280
Stara Zagora region,
Galabovo Municipality

Attn.: Todor Belezhkov

Reference: Supply of spare parts for ash disposal system manufactured by Diamond Power

Technical specification / 3. Delivery period

Our manufacturer Allen Sherman-Hoff, a division of Diamond Power confirms:

- The goods requested in the RFQ are STOCK items, meaning that the goods are ready for shipment 10 days (packing and organizing shipment) from official Purchase Order.
- The shipment overseas to Brno Czech Republic is estimated to be 6 weeks.

Furthermore, we confirm the following:

- Customs formalities and arrangements for further transportation to Bulgaria takes 4 days.
- Transportation to Galabovo, Bulgaria takes 2...3 days.

Alltogether, the delivery from Lancaster, Ohio, US to Galabovo, Bulgaria including customs clearance will be 9 weeks from official PO.

Date:

05.05.2016

Signature:

Juha Mustonen
Managing director

Diamond Power Central& Eastern Europe s.r.o.

Stamp:



Phone: +420 543 213 706 Fax: +420 543 213 706
Barvicova 685/41, 602 00 Brno, The Czech Republic
www.diamondpower-cee.com IČ: 283 99 641

пълно наименование на участника, търговски адрес, телефон и факс, ЕИК и ИН по ЗЛДС
 Diamond Power Central & Eastern Europe s.r.o., V Jirchářích 148/4, 110 00 Praha 1, Czech Republic,
 +420 543213705, fax +420 543213706, UIC 28399641, VAT registration number CZ28399641
 tel.

ТЕХНИЧЕСКО ПРЕДЛОЖЕНИЕ
TECHNICAL OFFER

към Оферта за участие в обществена поръчка чрез публична покана с предмет: „Доставка на резервни части за системата за пепелоизвозване
 производство на Diamond Power”, реф. № ME1-2016-NOA-D-039
 a part of the Offer for participation in a negotiated procedure without notice with subject: “Supply of spare parts for ash disposal system manufactured by Diamond
 Power, Ref. ME1-2016-NOA-D-039

No	Наименование и техническо описание (технически характеристики и параметри на детайлите) Name and technical description (technical characteristics of spare parts)	Мерна единица Unit	Кол-во Quantity	Производител и страна на произход Manufacturer and country of origin	Дата на доставка Delivery date	Гаранционен срок след доставка Warranty period after date of delivery	Забележка Notes
1	2 ASHCOLITE PIPE 10", L=18' Part Number: XF10P	3 бр. / pcs	4	5 DPII / Allen- Sherman-Hoff, US	6 1 седмица, Франко завода, опаковани 1 week Ex Works, packed	7 —	8 износване артикул, wear part
2	Pneumatic cylinder doc:ASH-PI-017 page.2 position.22 Part Number: 219364	бр. / pcs	6	Allen-Sherman- Hoff, US	1 седмица, Франко завода, опаковани 1 week Ex Works, packed	Една година, 1 year	

Списък на документите, съпровождащи стоката при доставка:
 List of documents accompanying the goods during shipment:

- Опаковъчен лист; / • Packing list;
- Приемно-предавателен протокол; / • Acceptance-delivery protocol;
- Сертификат за качество или Декларация за съответствие от производителя;
- Quality certificate and Declaration of conformity issued by manufacturer;
- Чертеж на изделието; / • Drawing of spare part;

ПОДСИС И ПЕЧАТ:
SIGNATURE AND STAMP:



Juhana Mustonen (име и фамилия) / (name and surname)
 05.05.2016 (дата) / (date)

управляващ директор, Managing director (длъжност на управляващия/представящата участника) / (title of Participant's manager/representative)
 Diamond Power Central & Eastern Europe s.r.o. (наименование на участника) / (Participant's name)



Appendix 3

Приложение 1 Attachment 1		Документ № ME1-MP-TRM-0077-A1 Doc. № ME1-MP-TRM-0077-A1				
Доставка на резервни части за системата за пепелопроизводство на "Diamond Power" Supply of spare parts for ash disposal system manufactured by "Diamond Power"						
КОЛИЧЕСТВЕНА СМЕТКА BILL OF QUANTITY						
№	Описание Description	Мат. Номер Material No	Мерна единица Unit	Количество Quantity	Единица Цена Unit price Euro	Стойност Amount Euro
1	ASHCOLITE PIPE 10", L=18' Part Number: XF10P		pcs	12	2257.50	27,090.00
2	Pneumatic cylinder doc:ASH-PI-017 page.2 position.22 Part Number: 219364		pcs	6	371.00	2,226.00
3	Транспортни разходи / Transport costs DDP Galabovo Incoterms 2010		pcs	1	8050.00	8,050.00
ОБЩО: SUM:						37,366.00
Забелжки: Notes:	<p>1. За коректно попълване на количествената сметка моля попълнете само жълтите полета. Please fill only yellow cells in the BOQ.</p> <p>2. Посочените цени да се попълват без ДДС. All the prices have to be without Value Added Tax (VAT)</p> <p>3. Посочените количества са ориентиривъчни. All quantities are tentative.</p> <p>4. Точните количества ще се формират на база реални нужди на възложителя. The exact quantities will be taken on the basis of real Client's needs.</p> <p>5. Плащането по договора ще се извърши на база доказани количества. The Client will pay only the delivered materials as per the Contract.</p>					

**ПОДПИС и ПЕЧАТ:
SIGNATURE AND STAMP:**

Juha Mustonen (име и фамилия) / (name and surname)

May 13, 2016 (дата) / (date)

управляващ директор, managing director (длъжност на управляващия/представяващия участника) / (title of Participant's manager)

Diamond Power Central & Eastern Europe s.r.o. (наименование на участника) / (Participant's name)



Diamond Power
Central & Eastern Europe

Diamond Power International, Inc. company
Phone: +420 543 213 700 Fax: +420 543 213 706
Sankovcova 685/41, 602 00 Brno, The Czech Republic
www.diamondpower-CEE.com IČ: 283 99 641

Appendix 5

AGREEMENT

on the rights and obligations of the Parties and on coordination of measures to ensure health and safety at work

1. Subject of the Agreement

- 1.1. This agreement establishes the requirements, rights and obligations of the parties to ensure health and safety at work of their workers and to protect the life and health of others who are in the area of their activities on the territory of the Contracting Entity.

2. General requirements

- 2.1. The employees of the Contracting Entity and the Contractor who organize and manage work processes shall be responsible for ensuring health and safety at work of the workers involved in the activities they manage. They shall immediately inform each other of all dangers and hazards.
- 2.2. No other activities except the agreed ones can be performed on the worksite or, by exception, activities subject to prior written permission by the Contracting Entity after special instruction of the Contractor's employees.
- 2.3. Movement of workers on site shall take place along designated routes, care being taken of any uneven surfaces, open shafts, moving vehicles and other marked or unmarked dangers threatening life and health.
- 2.4. If an activity is performed by employees of the Contracting Entity and of the Contractor in a single room and/or at two levels, the persons mentioned in Article 1 hereof shall take measures to ensure their mutual safety.
- 2.5. During work access shall be prohibited to any unauthorized persons who are not directly involved in the performance of the agreed activities.
- 2.6. Equipment, ladders and platforms used for work at height shall be standard and shall meet all safety requirements.
- 2.7. When carrying out hot works, employees of the Contracting Entity and the Contractor shall observe the fire safety rules. Smoking on the premises of the Contracting Entity is only allowed in the designated areas.
- 2.8. In case of or likelihood of occurrence of serious and imminent danger to life and health, the employees of the Contracting Entity and the Contractor shall immediately stop work until danger is eliminated.
- 2.9. During the execution of all works and activities under the Contract, the relevant applicable regulations and internal rules on health and safety at work shall be equally binding on both Parties.
- 2.10. Losses caused by worsening of quality and extending the timeframes of the performed work due to the dismissal of individuals or suspension of groups/teams for violations of the requirements under the rules and instructions on labor safety, industrial fire safety and environmental protection shall be at the expense of the Contractor.
- 2.11. Upon persistent breaches of the health and safety requirements by the Contractor, the Contracting Entity may unilaterally terminate the contract without owing any compensation to the other Party.

3. Rights and obligation of the Contracting Entity

- 3.1. Before commencement of the contractual work, the Contracting Entity shall conduct initial instruction and instruction at the worksite (if required) to the Contractor's staff as required by Ordinance RD-07-2 of 16 December 2009 on the conditions and procedures for conducting periodic training and instruction of employees on the rules to ensure healthy and safe working conditions, it records them in the relevant log. Conducting of all other types of instruction is the responsibility of the Contractor.
- 3.2. The Contracting Entity shall require from the Contractor a list of the names, certification documents (if required for a specific job) and certificates of acquired qualification group for all persons who will work on site and in the premises of the Contracting Entity.
- 3.3. The Contracting Entity shall provide safe access of employees and vehicles of the Contractor to the worksite for the duration of the Contract.
- 3.4. The Contracting Entity shall make the employees of the Contractor who organize and manage work processes familiar with the location of the serviced facilities, the specific characteristics of the worksite and the occupational hazards.
- 3.5. The Contracting Entity shall ensure the implementation of organizational and technical measures before admission of the Contractor's staff to work and also designate their worksites.
- 3.6. The Health and Safety Department (hereinafter referred to as HS) of the Contracting Authority is authorized to carry out monitoring for compliance with the requirements of safety and health at work. The instructions of its employees are binding to the Contractor's staff.
- 3.7. The Contracting Entity may dismiss from the worksite any Contractor's employees who are not familiar with the rules for health and safety at work, who do not observe them or do not have the necessary capacity, and also in case of serious and immediate risk to their health and life.
- 3.8. The Contracting Entity shall provide assistance to the Contractor including specialized equipment and staff in case of accidents, fires and/or incidents due to its fault.
- 3.9. the Contracting Entity shall duly inform the Contractor of any internal orders and decisions of the task forces related to its safety at work.

4. Rights and obligations of the Contractor

- 4.1. The Contractor shall provide qualified staff for the safe execution of the contractual activities.
- 4.2. The Contractor shall ensure that the persons who will carry out contractual activities are present at the initial instruction held prior to work commencement and at the instruction on the worksite as well as at any other instructions conducted by the Contracting Entity.
- 4.3. Before conduction of the initial instruction by the Contracting Entity, the Contractor shall submit a list of the names and the qualification group of each person, including the job managers and performers and the safety persons who will work on the site of the Contracting Entity.
- 4.4. When performing activities that require additional qualifications under the applicable regulations, the Contractor shall also furnish to the Contracting Entity the relevant qualification documents of its staff.

WPS

hm

- 4.5. The Contractor's staff shall while at work have on them their certificates of acquired qualification group in safety, as well as all documents proving the acquired qualifications.
- 4.6. The contractor is solely responsible for the provision and use of personal protective equipment by its employees.
- 4.7. The Contractor shall be responsible for the proper use of personal and collective protective equipment by its employees.
- 4.8. The Contractor shall ensure that its staff observes the instructions given by the Contracting Entity as well as the rules for health and safety at work and the relevant internal regulations in this regard.
- 4.9. The Contractor's staff may not commence work on the site of the Contracting Entity without any authorization by the authorized persons of the Contracting Entity.
- 4.10. The Contractor shall not allow removal of signs and fences, and also the Contractor may not carry out activities outside the designated worksite or block passages, corridors and platforms with dismantled assemblies, spare parts, waste materials and the like..
- 4.11. When performing the contractual activities, the Contractor shall not hinder the operational personnel to carry out safety walks and maintenance of the operating equipment and the redundant equipment items.
- 4.12. The Contractor shall ensure that its employees use appropriate tools in good condition and safe working equipment including proper and safe use of vehicles and the Contractor shall prevent them from using vehicles that are out of order.
- 4.13. The Contractor shall ensure that its staff appears to work after having good rest and shall not allow the use of alcohol or other intoxicating substances during the working hours as well as work under their influence.
- 4.14. The Contractor shall not allow persons to perform work, which they are not familiar with or do not possess relevant qualifications and competence.
- 4.15. The Contractor shall immediately inform the relevant employees of the Contracting Entity of any situation arising at work which might pose a serious and imminent danger to workers.
- 4.16. The Contractor may refuse to execute a certain job if there are reasonable doubts about the conditions related to health and safety of the workers provided by the Contracting Entity. The Contractor shall immediately notify the HS Department of the Contracting Entity about this situation.
- 4.17. In case of incidents and accidents with persons from the Contractor's staff, the head of the team shall immediately notify their management and the HS Department of the Contracting Entity, and then take measures and provide assistance in clarifying the circumstances and reasons of the accident.
- 4.18. The Contractor shall keep its worksites tidy, clean and safe. Upon completion of each portion of the work, the Contractor shall immediately remove from the worksite all of its plant, construction equipment, temporary structures and waste materials that will not be used at or near the same place during the later stages of work.
- 4.19. Contractor may at its discretion and in accordance with the regulations require additional measures to ensure safety at work.

WPS

5. Other conditions

5.1. The employees authorized by the Contracting Entity, upon identification of any breaches of the rules on labor safety made by the Contractor's staff, may:

- (a) give instructions or prescriptions for remedy of such breaches;
- (b) dismiss individual members or groups (teams) by stopping work if the breaches impose it;
- (B) give the Contractor suggestions in writing for sanctioning of persons who have made violations on the site of the Contracting Entity.

This supplementary Agreement prepared to meet the requirements of Article 14, Article 16, Article 18, Article 19 of the Health and Safety at work Act is an integral part of **CONTRACT 1051-AG-PPL** and it shall be in effect until expiry of the Contract.

Signed for and on behalf of **AES – 3 C Maritza East I EOOD**

Signature: _____

Name: Todor Belezhkov

Title: Plant Manager AES Bulgaria



Signed for and on behalf of the Contractor:

Signature: _____

Name: Juha Mustonen

Title: Managing Director of headquarters at Prague



Diamond Power International, Inc. company
Phone: +420 543 213 706 Fax: +420 543 213 706
Barvičova 685/41, 602 00 Brno, The Czech Republic
www.diamondpower-cee.com IČ: 283 99 641

Handwritten initials in blue ink.

Appendix 6

Procedure for sending and acceptance of invoices

1. Hard copy documents shall be sent by post to:

„AES Europe Services“ EOOD

Department: Processing of Incoming Invoices

1407 Sofia, j. k. Sredetz, Bulgaria

Blvd. „Cherni Vrah“ 32A, Aries Office Building, floor 1

Important: According to the Bulgarian tax requirements subject to processing are only original invoices. Scanned copies sent to the address emea.apinvoices@aes.com will be processed only if they are stamped and signed by the supplier with a "True copy".

2. Electronic invoices shall be sent to the common email address:

emea.apinvoices@aes.com

Issuing and sending your electronic invoices to this common email address will greatly contribute to more rapid and efficient processing of your documents and payment.

Please, consider in this case the following particulars, which are also a prerequisite for the efficient processing of documents:

- (a) Invoices shall be in Adobe PDF format;
- (b) If you are sending several invoices, you can attach just one invoice to an e-mail, so you will have to send as many e-mails as is the number of your invoices;
- (c) Each invoice can consist of more than one page;
- (d) Protocols shall be added as additional pages to the invoices;
- (d) Include in the Subject of your e-mail with an attached invoice to it the key word "Фактура" in Bulgarian or "Invoice" in English, for automatic and faster processing by the system;
- (e) If you have issued and sent an electronic invoice, you do not need to re-send a hard copy.

3. Hand-written invoices

If you still issue hand-written invoices, we would like to inform you that they cannot be read by the electronic scanning and automatic recognition system and since they need manual processing there might be some delays in their accounting and payment.

The Contracting Entity strongly recommends to you to avoid issuing hand-written invoices for your more efficient servicing!

new:

